

SUCTION CUPS AND VACUUM LIFTERS

SUCTION CUPS AND VACUUM LIFTERS



SUCTION CUPS

Clear Vinyl Suction Cups

SCV-0750-01 SCV-1500-01 SCV-1500-02 SCV-1500-03	Mini 3/4" diameter complete with knob 1-1/2" diameter complete with screw hole 1-1/2" diameter complete with metal hook 1-1/2" diameter complete with mushroom head
--	--

Machine Screw Type Suction Cups

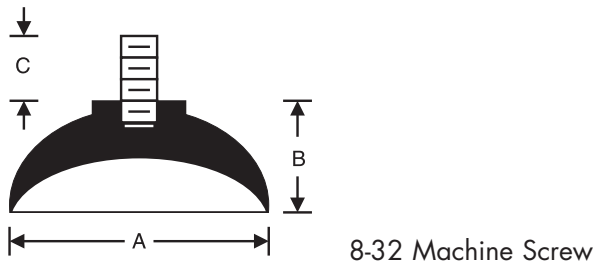

RPM Part Number	A Cup Diameter	B Cup Height	C Thread Length
SC-1000-01	1	7/16	1/4
SC-1375-01	1-3/8	1/2	3/8
SC-1500-01	1-1/2	1/2	3/8
SC-1750-01	1-3/4	5/8	3/8
SC-2125-01	2-1/8	3/4	1/2

All sizes have 8-32 steel brass plated machine screws securely bonded to cups.

Measured in inches

SC-1000-02

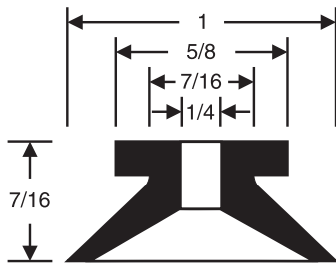

Beige 30 Duro

SC-1000-03

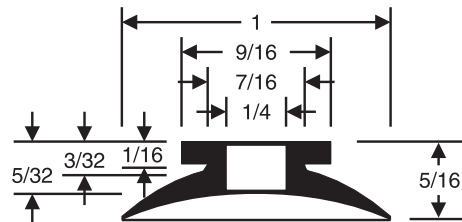

Beige 30 Duro

Measured in inches

SUCTION CUPS

SC-1313-01

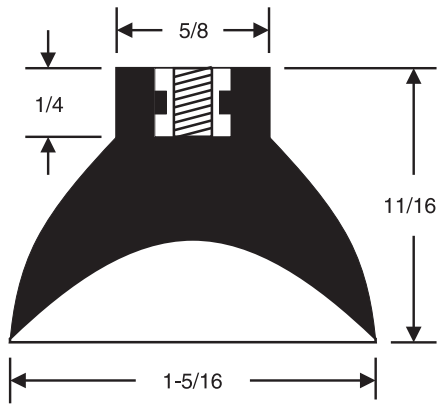

SC-1313-02

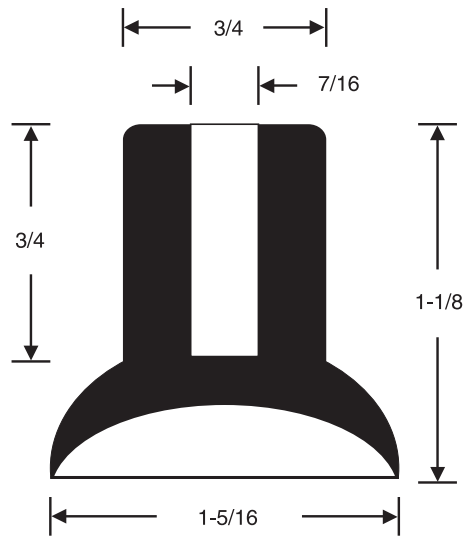

SC-1313-03

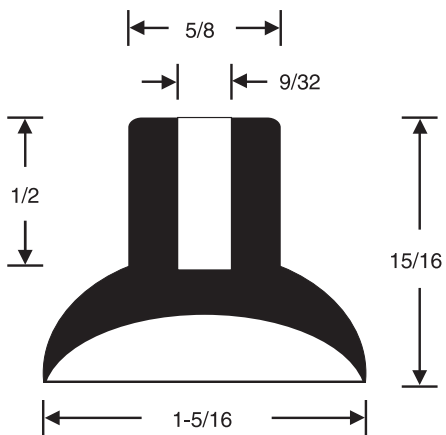

SC-1375-01-1/4

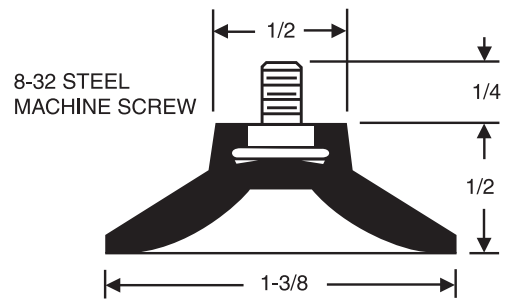

Measured in inches

SUCTION CUPS

SC-1500-01

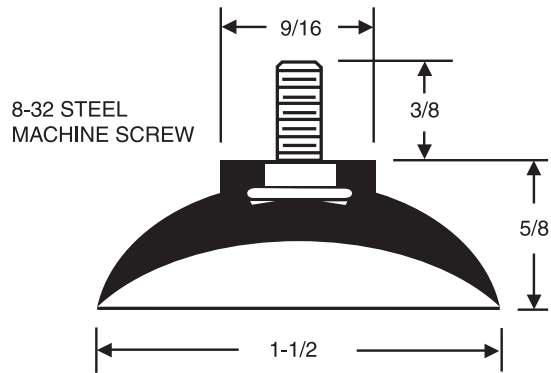

SC-1500-02

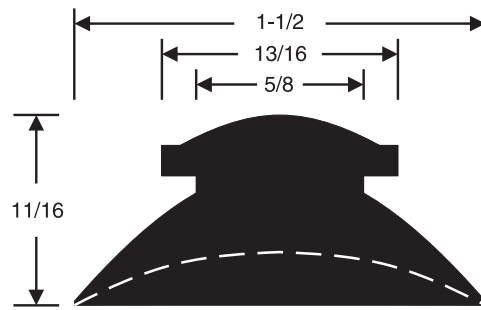

SC-3125-01 and SC-3125-02

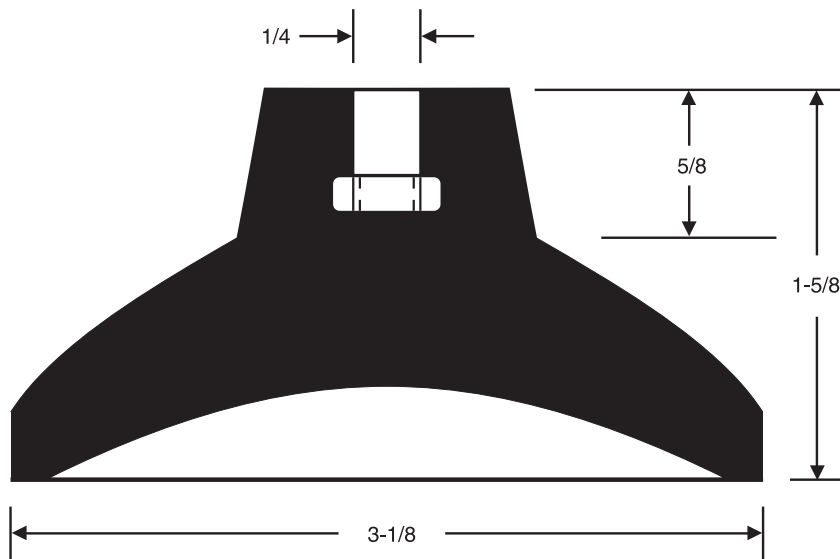

TWO STYLES

SC-3125-01 -
1/4-20 Nut Imbedded

SC-3125-02 -
1/4-20 x 3/8 Male Screw

Measured in inches

SUCTION CUPS

SC-3125-01

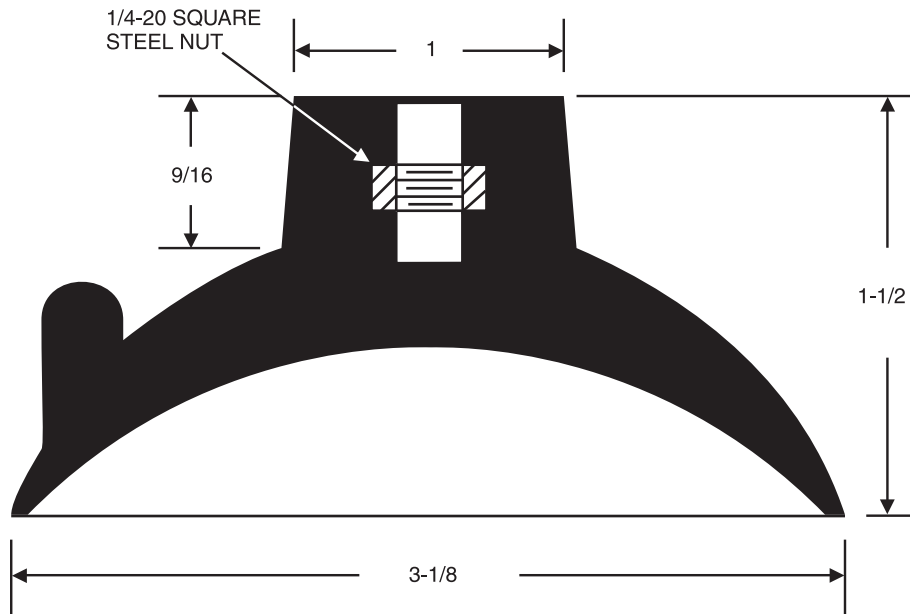

SC-3125-02

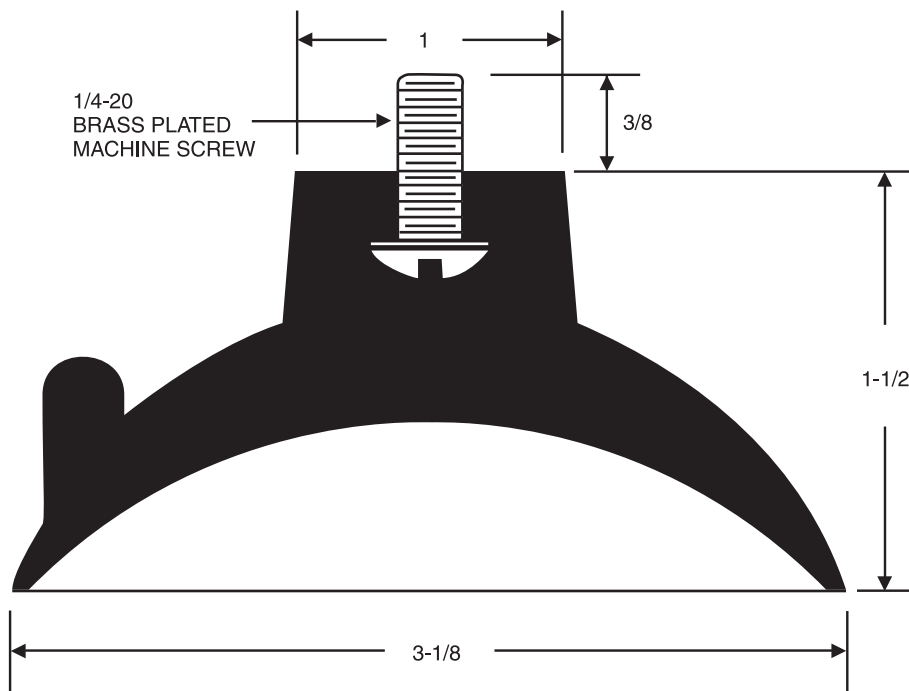

Measured in inches

SUCTION CUPS

62-RH

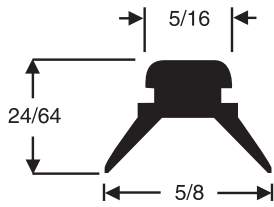

100-RH

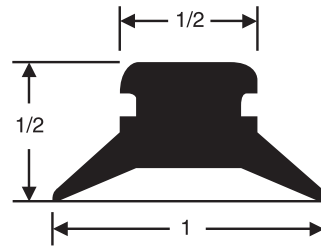

100-MS

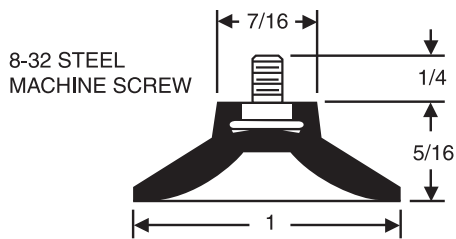

150-N

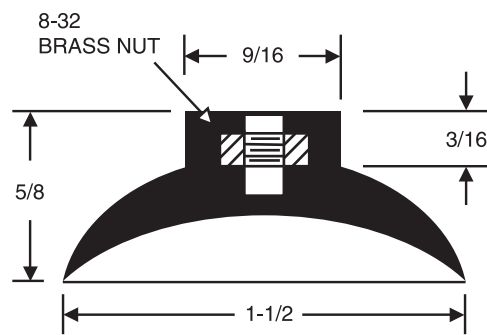

313-HN

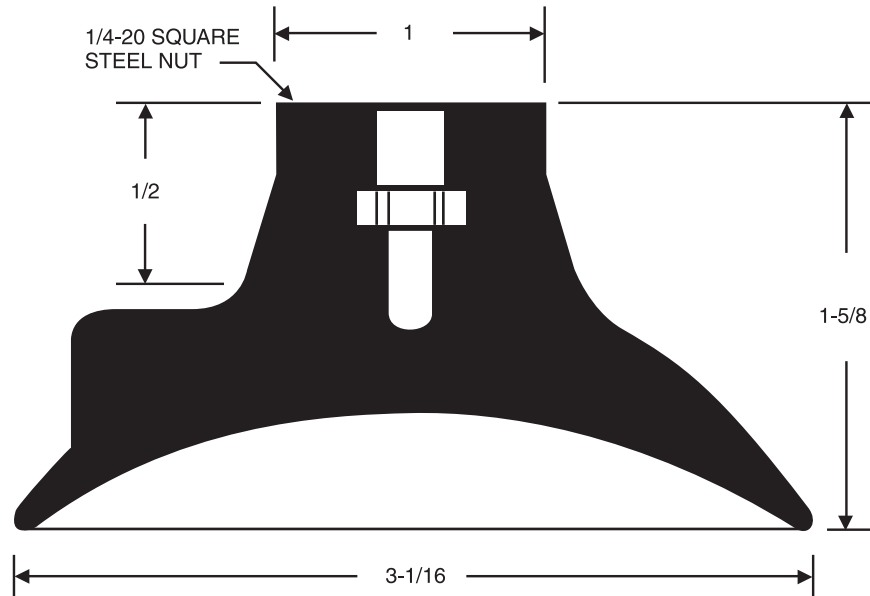

Measured in inches

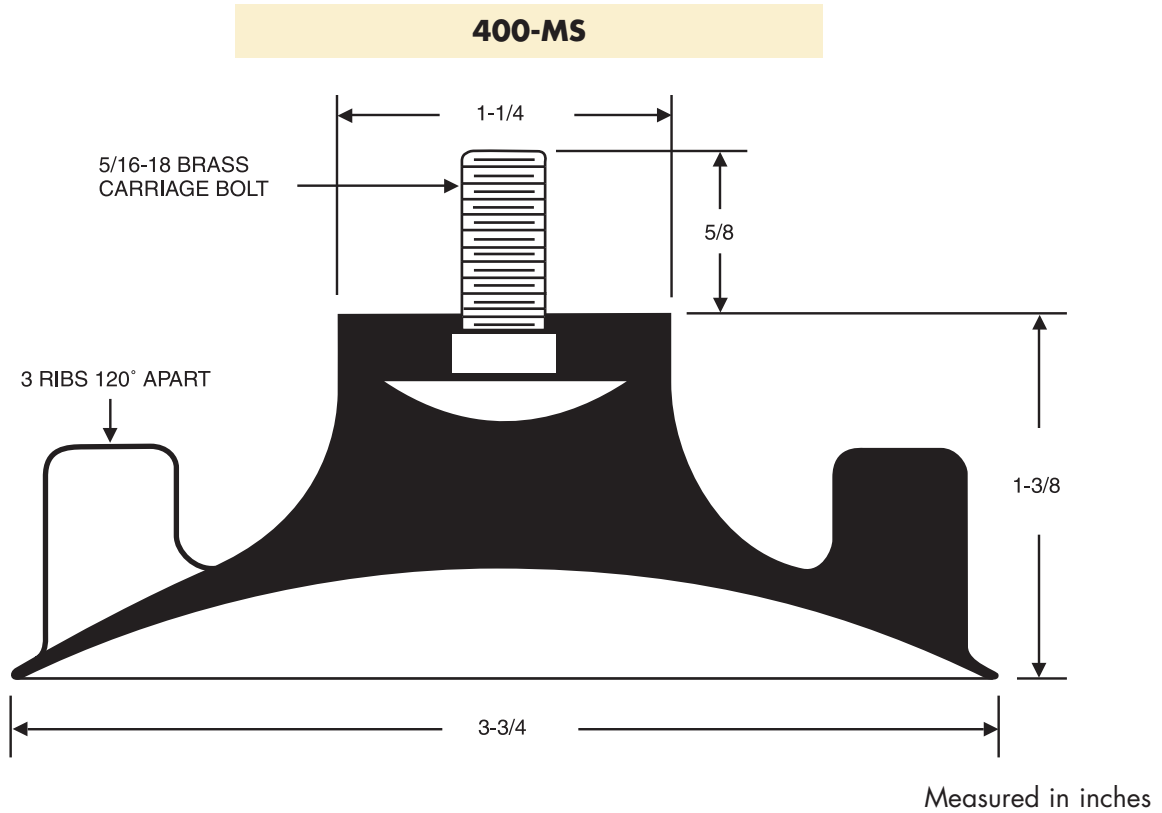

UNABLE TO FIND THE PART YOU REQUIRE?

Contact our customer service representative for information on the many additional standard or custom parts we have available.

VACUUM LIFTERS

Vacuum Material Handling Tools

- Grip and hold oiled or dry sheet metal, glass, plastics, and other smooth surfaces
- Keeps operators hands safely away from hazards and releases parts quickly
- Speed production work as much as 25% increase efficiency of operator
- Pistol-grip design allows easy, positive, holding even with bulky work gloves
- Eliminate costly damage to stock material
- All metal parts are precision made for extra durability

Safety programs require punch press operators to use a hand tool when feeding or removing work from the die, to avoid placing hands within the point of operation. We offer a full range of tools specifically designed for punch press use. They improve operator confidence, increase production up to 25% and cut down breakage.

Single Cup Lifters



Single 2-1/8" Cup		Single 3-1/4" Cup		Single 4" Cup	
No.	Handle	No.	Handle	No.	Handle
6464	12"	6467	12"	6470	12"
6465	15"	6468	15"	6471	15"
6466	18"	6469	18"	6472	18"

Double Cup Lifters



Double 2-1/8" Cup

- No. 6461** 12" handle
- No. 6462** 15" handle
- No. 6463** 18" handle

VACUUM LIFTERS

Two Man "Extra Heavy Duty" Handling Tool



Extra safety for operators and materials. Two operators can safely lift and carry large or heavy loads. Ideal for moving heavy gauge metal, marble slabs and heavy plate glass.

No. 3700 2 Cups 4" each

No. 3750 2 Cups 5" each

Heavy Duty Double Cup (Sheet Metal Handling Tool)



Versatile one or two hand lifting. The 5" cups safely lift weights far beyond operator's normal capacity. Simultaneous trigger release.

No. 6540 2 Cups 4" each

No. 6541 2 Cups 5" each

Heavy Duty (Sheet Metal Handling Tool)



Lifts heavy loads safely. Powerful suction grips material and holds until released by hand trigger. Use for loading, unloading, piling and shifting loads.

No. 1859 4" Cup

No. 1912 5" Cup

The Little Grabber



One-finger tool for lifting light objects or raising corners. Leaves hand free for other work. Easy-release tabs.

No. 5157 2-5/8" Cup

No. 1230-3 2-1/8" Cup,
1-1/4" Finger Hole.

No. 1230-3-OLD 2-1/8" Cup,
1" Finger Hole.

VACUUM LIFTERS

The Knuckle Saver



Two-finger grip and larger cup for heavier loads. Breaks oil adhesions easily. Release tabs.

No. 3825 3-1/4" Cup

Super Grabber



Big 4-3/4" diameter. No metal parts – all rubber composition. Four-finger style for super gripping action, with easy release tabs.

No. A4875 4-3/4" Cup

Grifter



Combination grabber and lifter combines the flexibility of a grabber with the holding strength of a lifter. Just lift lipped edge to release vacuum.

No. G609 3-1/4" Cup

Medium Duty Handling Tool



Full hand grip for extra strength and fingertip pushbutton release speeds handling of smooth materials safely.

No. 2260 3-1/4" Cup

UNABLE TO FIND THE PART YOU REQUIRE?

Contact our customer service representative for information on the many additional standard or custom parts we have available.